

HEAVY PARTS WELDING FABRICATOR



Plant is located in Mukachevo, Transcarpathia, on the M06 international highway, 30-50 km from the borders with Romania, Hungary, Slovakia and Poland. The nearest airports are Kosice (Slovakia) -140 km, Lviv (Ukraine) -220 km and Budapest (Hungary) -260 km.

The total territory of the plant is 8.2 hectares. The total area of production premises is more than 30,000 m², including 15,000 m² under one roof.

PRODUCTION FACILITIES

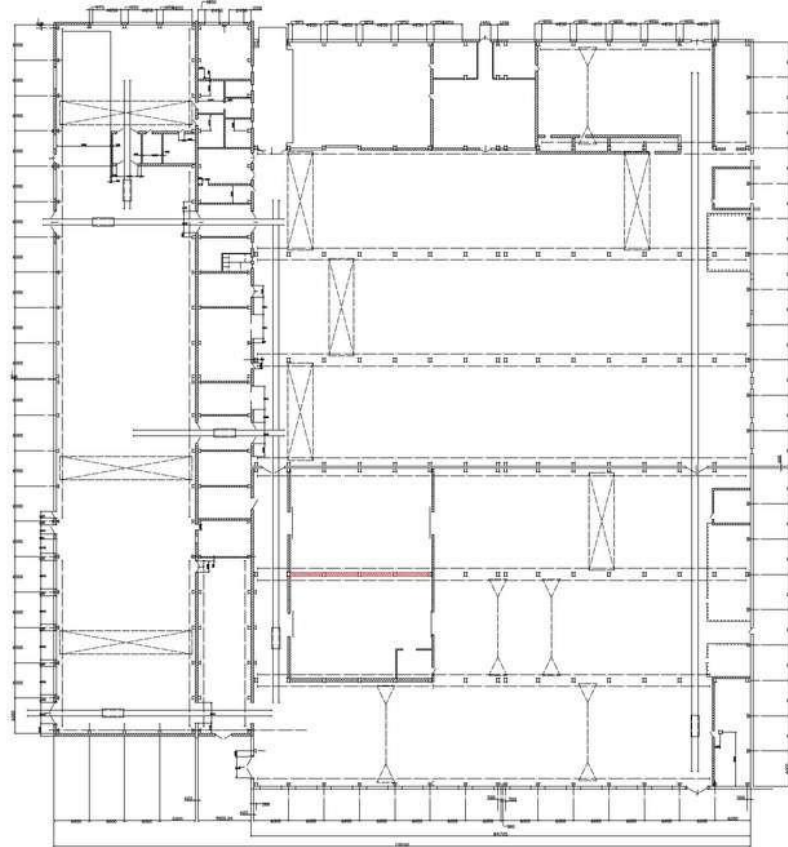

Main hall:
6 bays of 80 x 18 m,
1 bay 80 x 24m,

Hall 2:
1 bay 80 x 24m,

Hall 3:
3 bays of 40 x 12 m,

Hall 4:
2 bays 30 x 18m,

Cranes from 3 to 10 tons

MACHINERY AND EQUIPMENT



OVER 100 UNITS OF EQUIPMENT ARE BEING USED AT OUR PRODUCTION AREAS CARRYING OUT THE FOLLOWING OPERATIONS:

Metal cutting:

- Laser (2,000 x 6,000mm)
- Plasma (2,600 x 12,000mm)



Band saws (pipes and profiles up to Ø400mm)

Bending on CNC press-brakes

- 2 500MM, 135T
- 6 000MM, 200T



MACHINERY AND EQUIPMENT



Machining of parts:

- CNC milling up to 1,300 mm;
- Milling up to 6,000 mm;
- Boring up to 1,200 mm;
- Turning and other operations

Welding equipment:

- Semi-automatic MIG/MAG machines up to 500A;
- TIG semi-automatic machines;
- Automated welding

MACHINERY AND EQUIPMENT



Painting:

- Shot blasting booth –22,0 m;
- Wet paint spray booth –22,0 m;
- Powder coating –1,0 m x 2,0 m;
- Wagner painting equipment



JIGS AND FIXTURES



MMZ internally develops and manufactures jigs and fixtures that ensures geometric dimensions and repeatability of serial products.

CERTIFICATES

The factory is certified according to international quality standards:

ISO 9001, ISO 3834, EN 15085-2 CL1

Welders are certified in accordance with the requirements of international standards

The quality assurance program guarantees the high performance of our products

QUALITY



Long-term partnerships with our customers are primarily ensured by impeccable product quality.

Incoming, in process and 100% final quality controls are the measures that are systematically used.



Product quality is confirmed by 3D measurement protocols of product geometry, as well as ultrasound control of welded joints.

Products examples: special wagon



Products examples: special trailer frames



Products examples : special equipment chassis

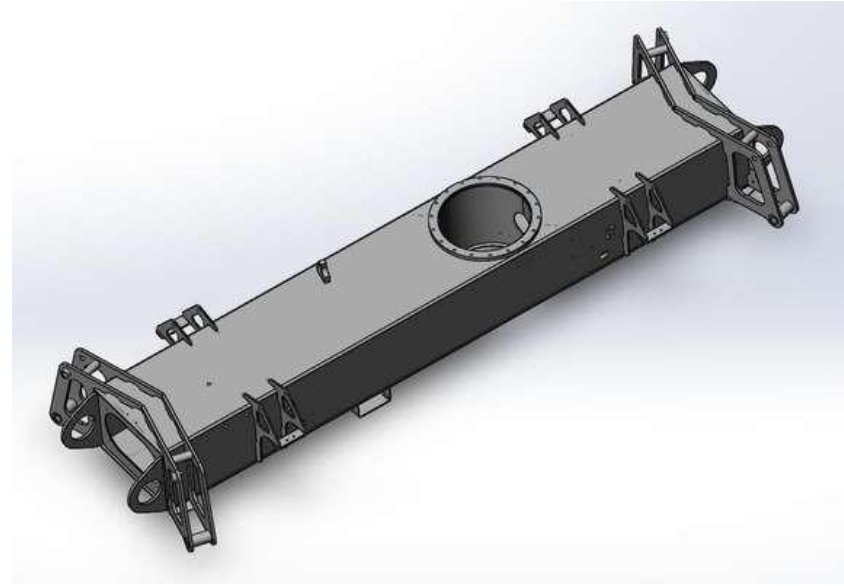

Products examples : special equipment chassis





BIG WELDING PARTS FABRICATOR

Thank you!